

## 50 Gb/s 2: 1 SELECTOR

### Features

- Maximum output rate in multiplexing mode: 50 Gb/s
- Output amplitude: 0.9 V<sub>pp</sub>
- Single-ended inputs

### General Description

The CI0086 is a 2: 1 selector operating at rates up to 50 Gb/s output. The I/O levels are SCFL (V<sub>H</sub>: 0.0 V, V<sub>L</sub>: -0.9 V). The IC is fabricated using a 0.1- $\mu$ m InP HEMT process. The CI0086 is provided in a hermetically-sealed package with V-connectors.

### Applications

- 2: 1 Multiplexer

### Functional Diagram

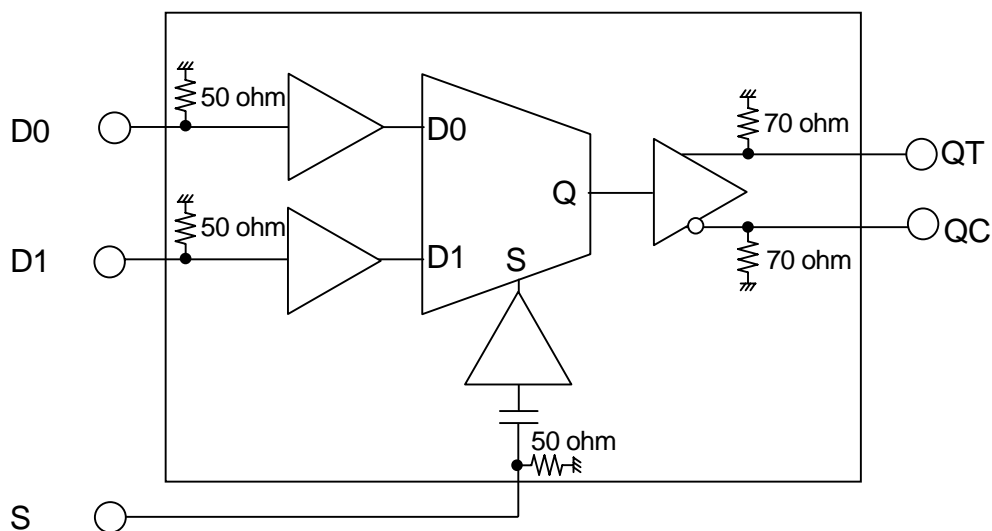

### Timing Chart

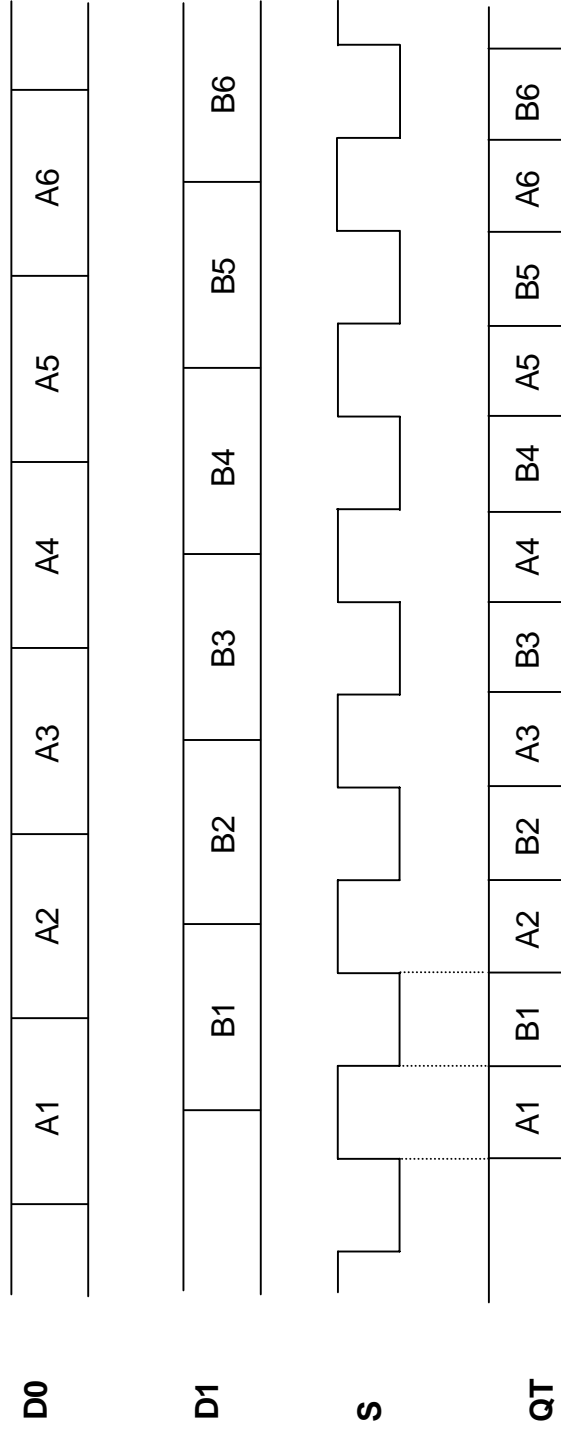

### Connection Table

No.	NAME	FUNCTION	No.	NAME	FUNCTION
1	NC	No Internal Connection	8	QT <sup>(2)</sup>	Data Output (True)
2	S	Select Signal Input	9	QC <sup>(2)</sup>	Data Output (Complementary)
3	GND	Ground (0.0 V)	10	GND	Ground (0.0 V)
4	Vrefd0 <sup>(1)</sup>	Data Input 0 Reference	11	Vss	Power Supply (-4.5 V)
5	D0	Data Input 0	12	D1	Data Input 1
6	NC	No Internal Connection	13	Vrefd1 <sup>(1)</sup>	Data Input 1 Reference
7	GND	Ground (0.0 V)	14	GND	Ground (0.0 V)

#### Notes

- (1) Adjust Vrefd0 and Vrefd1 in the range between -0.75 V and -0.2 V.
- (2) Terminate unused output to GND through 50 ohm resistors.

### Connection Diagram (Top View)

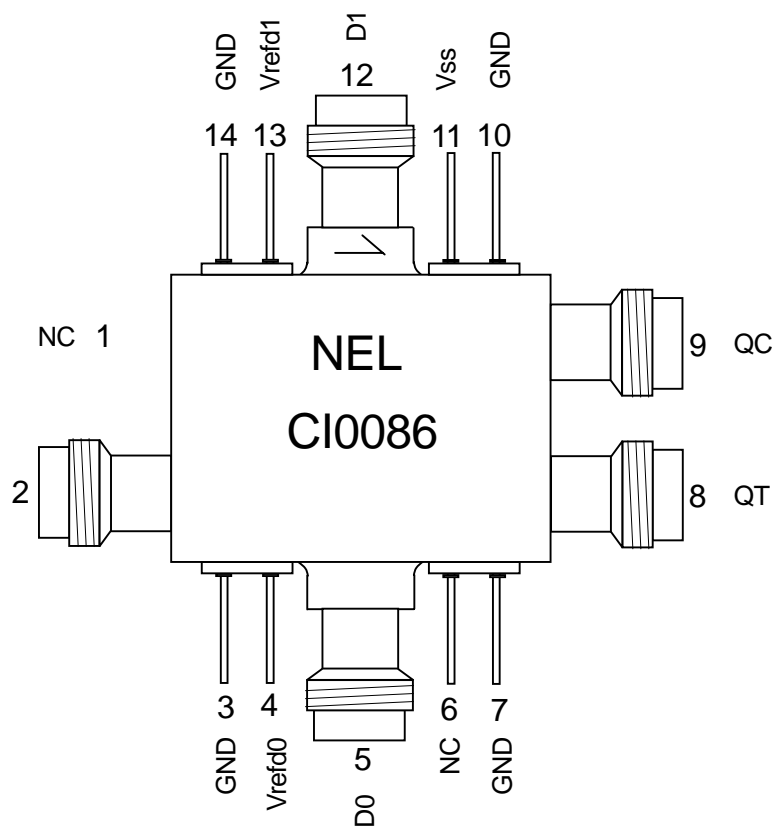

## Absolute Maximum Ratings

SYMBOL	PARAMETER	RATING	UNIT
VSS	Power Supply Voltage	-5.0 to +0.1	V
Vin	Applied Voltage Amplitude at Select Signal Input (S)	1.2	Vpp
Vind	Applied Voltage at Data Inputs (D0, D1)	-1.2 to +0.1	V
Vins	Applied Voltage at Select Signal Input (S)	-1.2 to +1.2	V
Vout	Applied Voltage at Data Outputs (QT, QC)	-1.5 to + 0.2	V
Vrefd	Applied Voltage at Vrefd0 and Vrefd1 pin	-1.2 to +0.1	V
Tstor	Storage Temperature	TBD	°C
Tc <sup>(1)</sup>	Case Temperature under Bias	TBD	°C

TBD: To Be Determined

## Recommended Operating Conditions

SYMBOL	PARAMETER	MIN.	TYP.	MAX.	UNIT
VSS	Power Supply	-4.7	-4.5	-4.3	V
Vrefd0	Data Input Reference Voltage	Adjust in the range from -0.75 V to -0.2 V			
Vrefd1					
D0	Data Input Interface	DC coupling (see DC Characteristics)			
D1					
S	Select Signal Input Interface	DC coupling (see DC Characteristics) or AC coupling (see AC Characteristics)			
QT, QC	Data Output Interface	DC coupling (see DC Characteristics) , Terminate to GND through 50 ohm			

## DC Characteristics

(V<sub>SS</sub> = -4.5 V, GND = 0.0 V, Tc<sup>(1)</sup> = 30 °C)

SYMBOL	PARAMETER	MIN.	TYP.	MAX.	UNIT
ISS	Power Supply Current		420	TBD	mA
VOH	Output Voltage, High (QT, QC)	TBD	0.0		V
VOL	Output Voltage, Low (QT, QC)		-0.9	TBD	V
VIH	Input Voltage, High (D0, D1, S)	TBD	0.0		V
VIL	Input Voltage, Low (D0, D1, S)		-0.9	TBD	V

TBD: To Be Determined

Note

(1) Tc: Temperature at package base.

## AC Characteristics (50 GHz)

(V<sub>ss</sub> = -4.5 V, GND = 0.0 V, V<sub>refd0</sub> and V<sub>refd1</sub>: Adjust in the range from -0.75 V to -0.2 V)

SYMBOL	PARAMETER	T <sub>c</sub> =30 °C			UNIT
		MIN.	TYP.	MAX.	
V <sub>in</sub>	Select Signal Input Voltage Amplitude	TBD	0.9		V <sub>pp</sub>
f <sub>MAX</sub>	Maximum Output Data Rate	50			Gb/s
S <sub>MIN</sub>	Minimum Select Signal Frequency		10		GHz
V <sub>amp</sub>	Output Voltage Amplitude (QT, QC)	TBD	0.9		V <sub>pp</sub>
t <sub>r</sub>	Output Rise Time (QT, QC) 20 - 80%		10	TBD	ps
t <sub>f</sub>	Output Fall Time (QT, QC) 20 - 80%		10	TBD	ps

## Sample Waveforms (50 Gb/s)

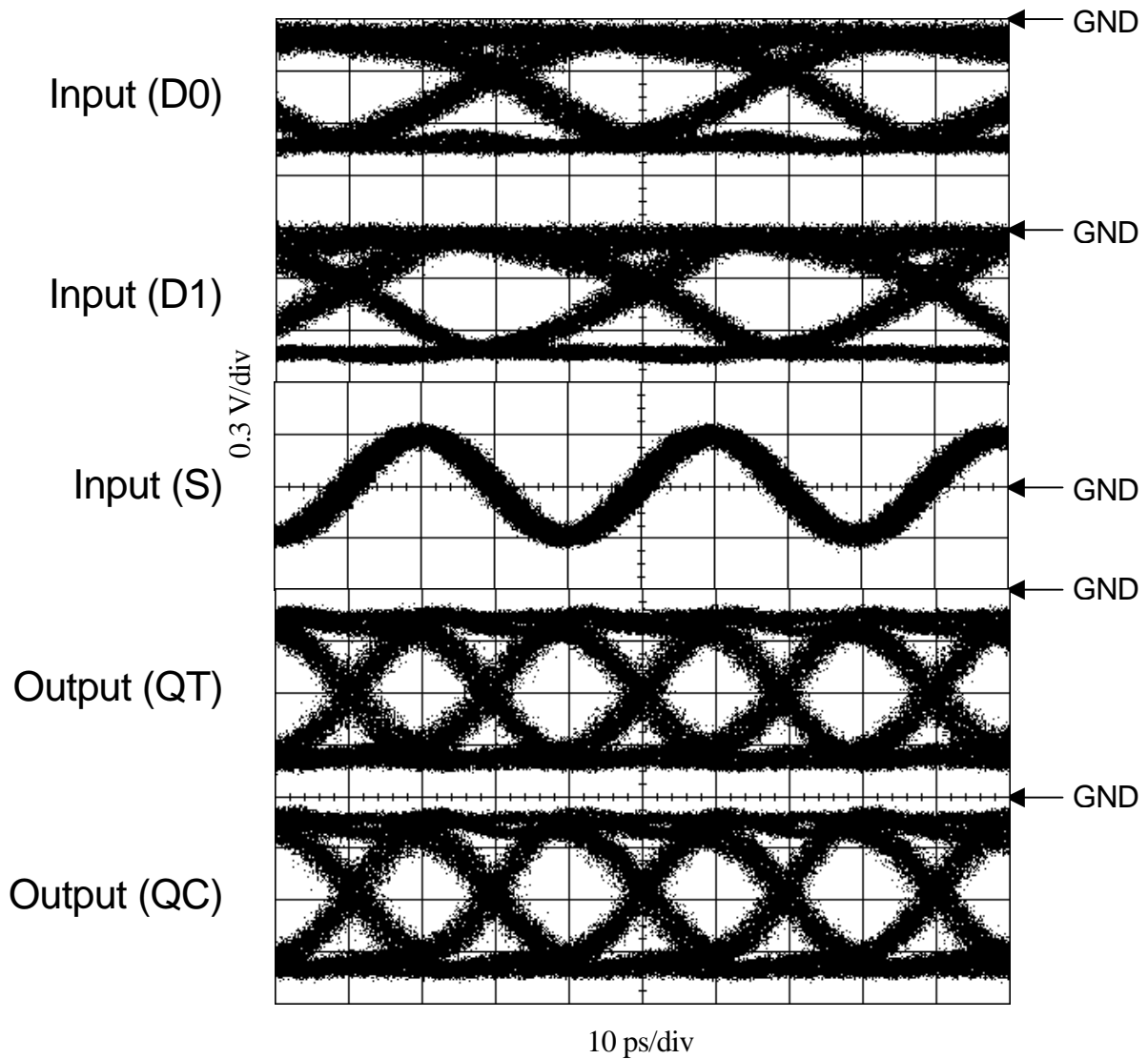

### Measurement Conditions

$V_{ss} = -4.5$  V, Vrefd0: Optimum, Vrefd1: Optimum

Input Data: 25 Gb/s

Input Select Signal: 25 GHz



**SCMD Package Dimension (mm)**

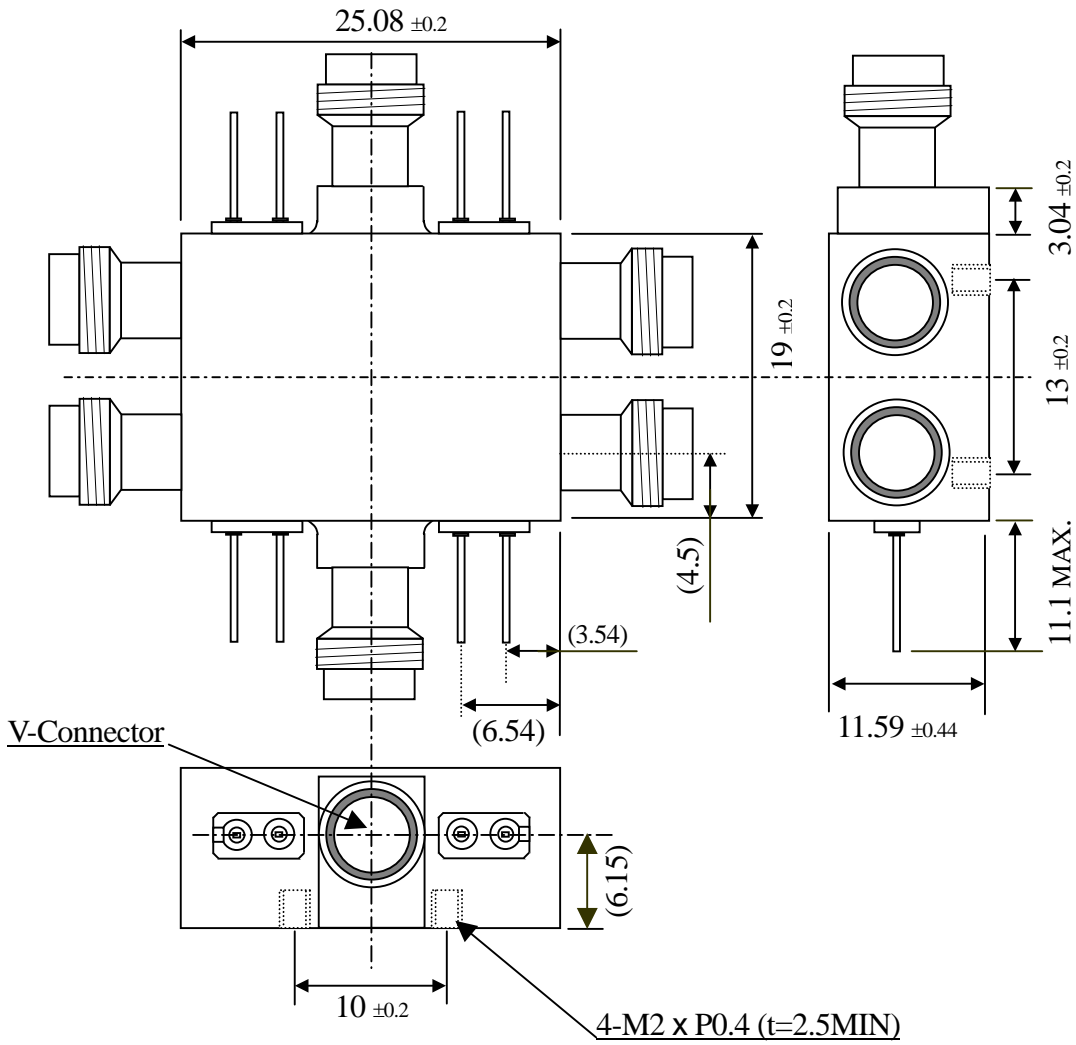

## Handling Instructions

Since the IC is fabricated using InP HEMT process, users are recommended to follow the instructions below to prevent damage to the chip from electro-static discharge.

- 1) Use a conductive working desk connected to the ground (or, a conductive table top connected to the ground).
- 2) Require all handling personnel to wear a conductive bracelet or wrist-strap connected to the ground through a 1 M-ohm resistor.
- 3) Ground all test equipment.
- 4) Ground all soldering iron tops.
- 5) Store IC's and other devices such as chip capacitors in their conductive carriers until they are soldered.

## Caution

1. In order to improve products and technology, specifications are subject to change without notice.
2. When using the products, be sure the latest information and specifications are used.
3. Circuit drawings etc. shall be provided for the purpose of information only on application examples not for actual installation of equipment. NTT Electronics Corp. shall not assume any liability for damage that may result from the use of these circuit drawings etc. NTT Electronics Corp. shall not assent to or guarantee any rights of execution for patent rights of the third parties and other rights that may be raised for use of these circuit drawings.
4. To make a design, the products shall be used within the assured ranges with respect to maximum ratings, voltage, and radiation. NTT Electronics Corp. shall not take any responsibility for damage caused by neglecting the assured values or improper usage.
5. Though NTT Electronics Corp. makes every effort to improve quality and reliability, there is a risk that failure or malfunction may occur in semiconductors. It is therefore necessary that the purchasers should take responsibility for making a design that allows the products to operate safely on equipment and systems without any direct threat to the human body and/or property, should such failures or malfunction occur.
6. NTT Electronics Corp.'s semiconductor device products are designed to be used with multimedia networks communication equipment and related measuring equipment. They have not been developed for such equipment that may affect people's lives. Those who intend to use the products for special purposes that may affect human life as a result of failure or malfunction in the equipment using the products or that require extremely high reliability (e.g. life support, aircraft and space rockets, control in nuclear power facilities, submarine relays, control of operations, etc.) shall contact NTT Electronics Corp. before using the products. NTT Electronics Corp. shall not assume any liability for damage that may occur during operation of the products without prior consultation.
7. The product is controlled under the 'Foreign Exchange and Foreign Trade Law'. In the case of exporting this product, it is requested that you take necessary procedures to obtain prior approval from the Minister of Economy, Trade and Industry.
8. The product uses arsenic compound. Arsenic compound powder and vapor are dangerous for humans. Do not break, cut, crush or chemically destroy the products. To dispose of the products, follow the relevant regulations and laws; do not mix with general industrial waste and domestic garbage.
9. Any questions should be directed to the Sales Department of NTT Electronics Corp.

Copyright 2007  
NTT Electronics Corp.