

43 Gb/s Data Limiting Amplifier

Features

- Data bit rate : DC - 43 Gb/s
- Saturated output voltage amplitude : 0.9V_{pp}
- Small signal gain : 20dB

General Description

The CI0401 is an ultra-fast InP HEMT Limiting Amplifier operating at rates up to 43 Gb/s. The IC is fabricated using a 0.1- μ m InP HEMT process. The CI0401 is provided in a hermetically-sealed package with V connectors.

Applications

- Optical communication system.
- Test equipment

Truth Table

Din	QT	QC
L	L	H
H	H	L

Functional Diagram

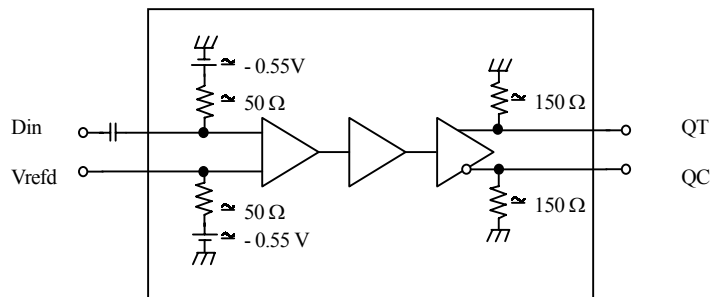

Connection Table

No.	NAME	FUNCTION	No.	NAME	FUNCTION
1	NC	No Internal Connection	8	QT ⁽¹⁾	Data Output (True)
2	Din ⁽²⁾	Data Input	9	QC ⁽¹⁾	Data Output (Complementary)
3	GND	Ground (0.0 V)	10	GND	Ground (0.0 V)
4	NC	No Internal Connection	11	Vss	Power Supply (-4.5 V)
5	NC	No Internal Connection	12	NC	No Internal Connection
6	NC	No Internal Connection	13	Vrefd ⁽²⁾	Data Input Reference
7	GND	Ground (0.0 V)	14	GND	Ground (0.0 V)

Notes

- (1) Terminate unused output connectors to GND through 50-ohm resistors.
- (2) Internally generated reference voltage that determines the data input threshold level. By Applying $-0.75V$ to $-0.35V$ externally to this pin an arbitrary threshold voltage can be established.

Connection Diagram (Top View)

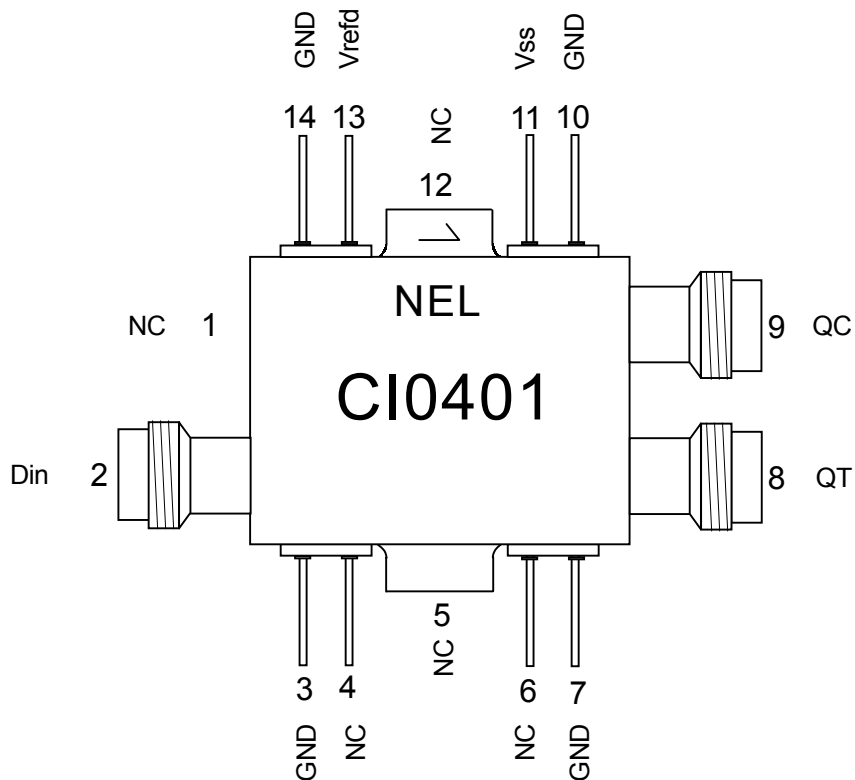

Absolute Maximum Ratings

SYMBOL	PARAMETER	RATING	UNIT
V _{ss}	Power Supply Voltage	-5.0 to +0.1	V
V _{in}	Applied Voltage Amplitude at Data Input (Din)	1.2	V _{pp}
V _{ind}	Applied Voltage at Data Input (Din)	-1.2 to +0.1	V
V _{refd}	Applied Voltage at V _{refd} pin (V _{refd})	-1.2 to +0.1	V
V _{out}	Applied Voltage at Data Outputs (QT, QC)	TBD	V
T _{stor}	Storage Temperature	TBD	°C
T _c ⁽¹⁾	Case Temperature at Package base under Bias	TBD	°C

TBD: To Be Determined

Recommended Operating Conditions

SYMBOL	PARAMETER	MIN.	TYP.	MAX.	UNIT
V _{ss}	Power Supply	-4.7	-4.5	-4.3	V
V _{refd}	Data Input Reference Voltage	Open or Adjust in the range from -0.75 V to -0.35 V			
Din	Data Input Interface	AC coupling (see AC Characteristics)			
QT, QC	Data Output Interface	DC coupling (see DC Characteristics) , Terminate to GND through 50 ohm			

DC Characteristics

(V_{ss} = -4.5 V, GND = 0.0 V, T_c⁽¹⁾ = 30 °C)

SYMBOL	PARAMETER	MIN.	TYP.	MAX.	UNIT
VOH	Output Voltage, High (QT, QC)	TBD	0.0		V
VOL	Output Voltage, Low (QT, QC)		-0.9	TBD	V
ISS	Power Supply Current		130	TBD	mA
Pd	Power Dissipation		0.6	TBD	W

TBD: To Be Determined

Note

(1) T_c: Temperature at package base.

AC Characteristics

(V_{SS} = -4.5 V, GND = 0.0 V, PN = 31, MR = 1/2, V_{refd} : Adjust in the range from - 0.75 V to - 0.35 V)

SYMBOL	PARAMETER	Tc=30 °C			UNIT	
		MIN.	TYP.	MAX.		
f _{MAX}	Maximum Data Operating	43			Gb/s	(1)
t _r	Output Rise Time (QT, QC) 20 - 80%		10	TBD	ps	(2)
t _f	Output Fall Time (QT, QC) 20 - 80%		10	TBD	ps	(2)
V _{ampsat}	Saturated Output Voltage Amplitude (QT, QC)	TBD	0.9	TBD	V _{pp}	(2)
V _{inmin}	Minimum Input Sensitivity (Din)		250	TBD	mV _{pp}	(3)
S21	Small signal gain	See page 6				

TBD: To Be Determined

Notes

- (1) Confirmed by error-free operation using a pseudo-random pattern having a word length of $2^{31}-1$ bits .
- (2) V_{ampsat} is a saturated output voltage amplitude for data input voltage amplitude of 0.6 V_{p-p} at the condition of 43 Gb/s.
- (3) V_{inmin} is the minimum data input voltage to obtain the error-free operation at the condition of 43Gb/s pseudo-random pattern having a word length of $2^{31}-1$ bits.

Sample Input and Output Waveforms (43 Gb/s)

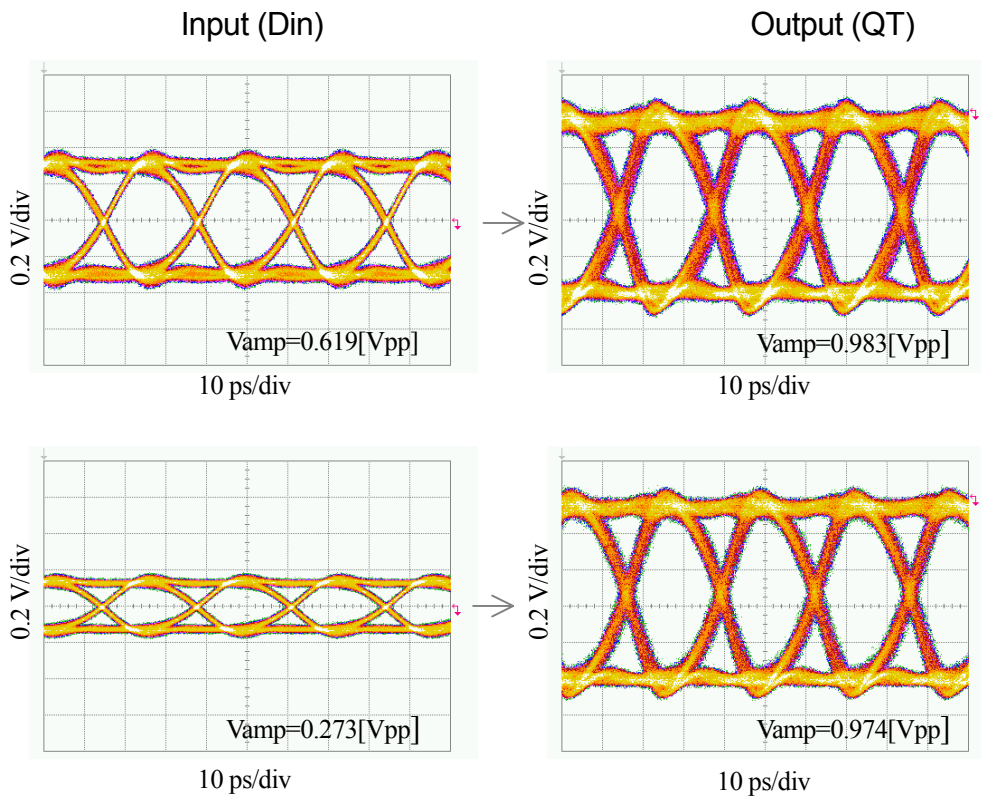

Measurement Conditions

$V_{ss} = -4.5 \text{ V}$

Din : 43Gb/s, PN=31,MR=1/2, AC coupling

Vrefd : -0.542 V

QT, QC : DC coupling

Data output connected to 50 – ohm impedance pins of a sampling oscilloscope with a 70GHz BW sampling head and precision time base module.

Sample INPUT AND OUTPUT CHARACTERISTICS (43 Gb/s)

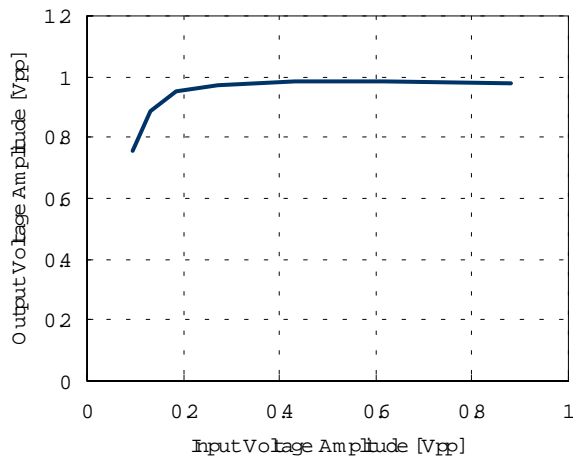

Measurement Conditions

V_{ss} = - 4.5 V

Din : 43Gb/s, PN=31,MR=1/2, AC coupling

V_{refd} : -0.542 V

QT, QC : DC coupling

Data output connected to 50 – ohm impedance pins of a sampling oscilloscope with a 70GHz BW sampling head and precision time base module.

Sample S21 CHARACTERISTICS

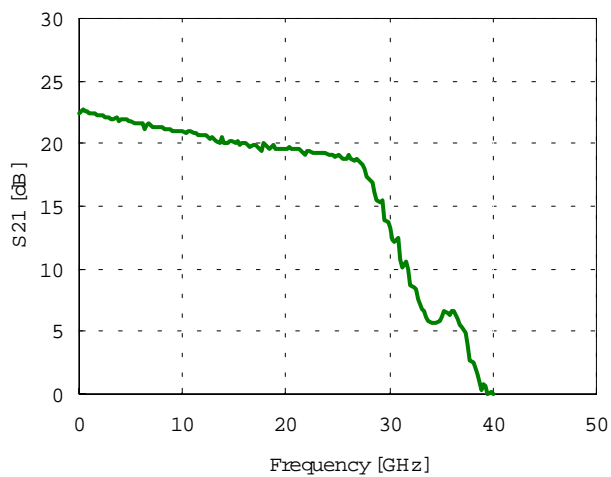

Measurement Conditions

V_{ss} = - 4.5 V

V_{refd} : -0.542 V

QT : DC coupling

QC : terminated

Sample Implementation

Note: Each number corresponds to a pin or a connector as shown in Connection Diagram.

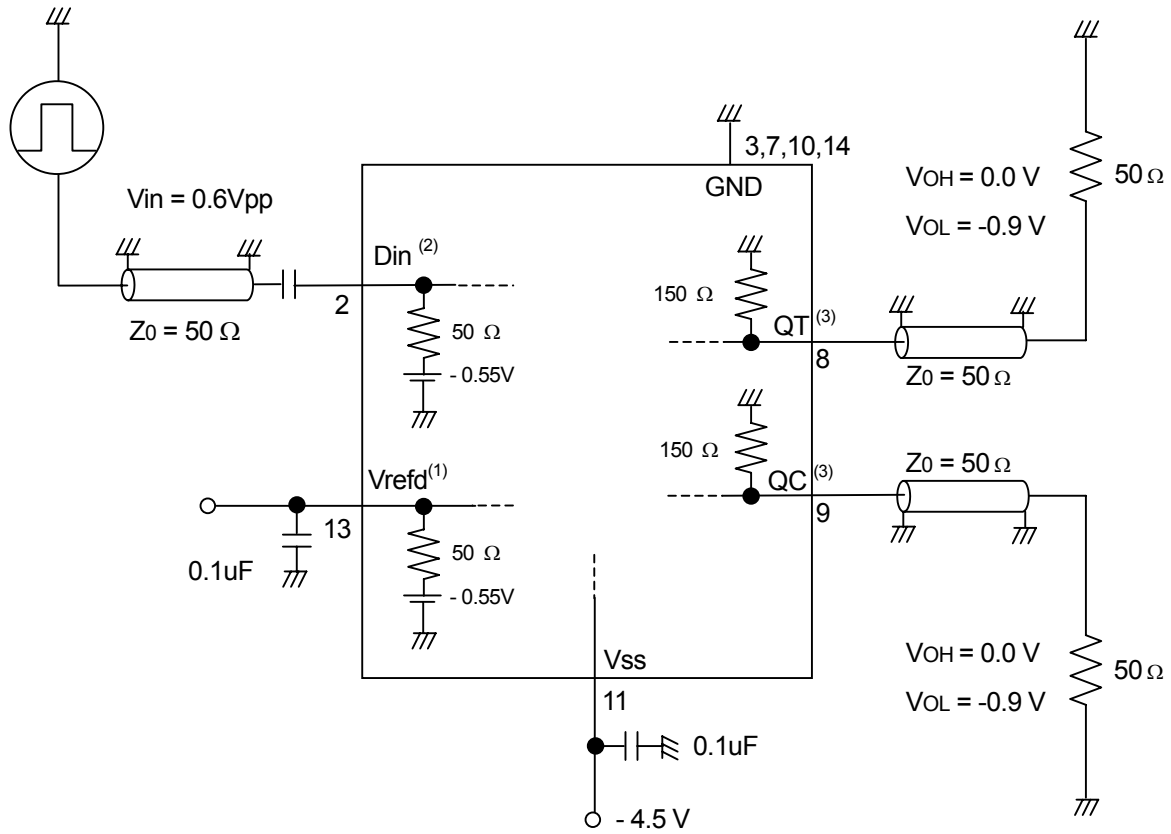

Note

- (1) Open or adjust in the range from -0.75 V to -0.35 V .
- (2) AC coupling with external capacitor.
- (3) DC coupling only.

SCMD Package Dimension (mm)

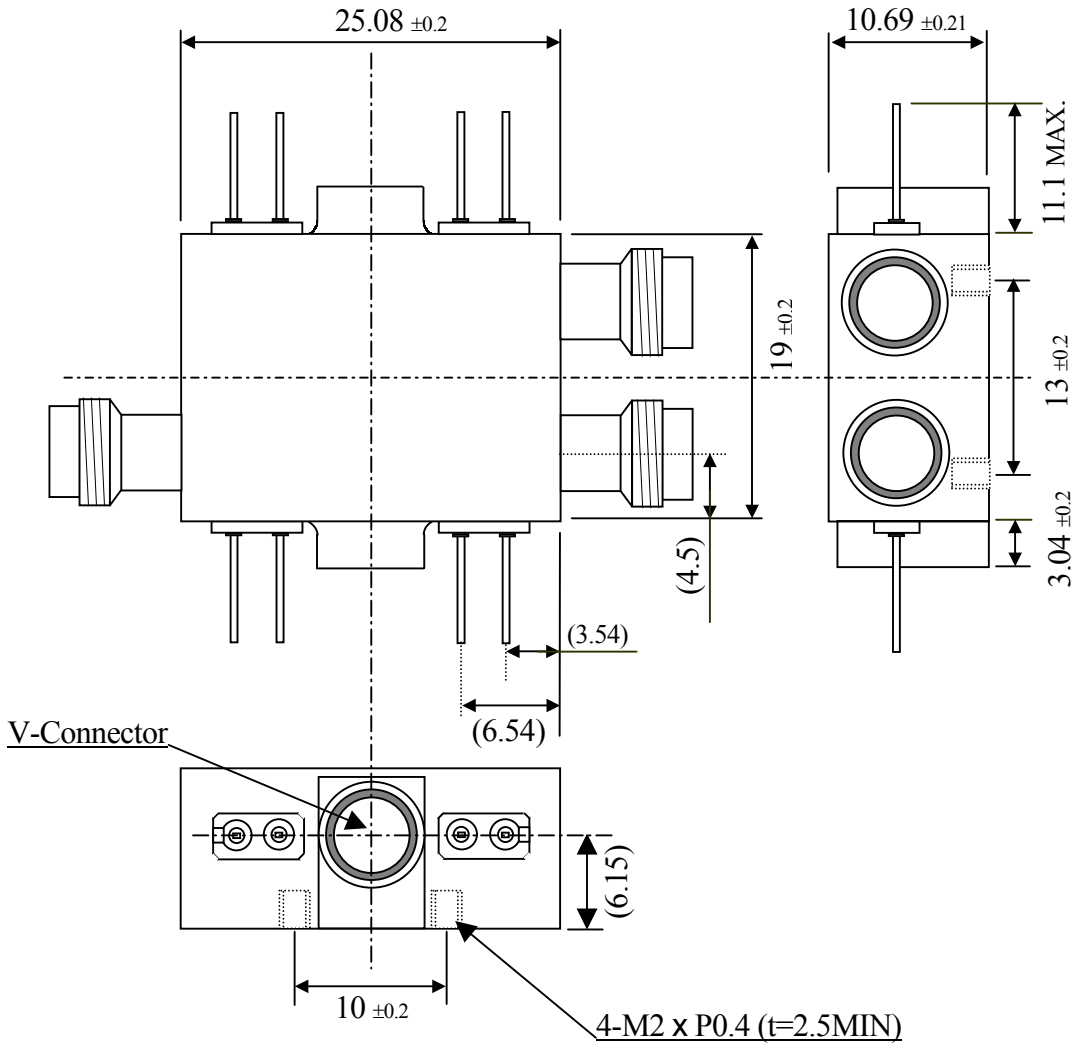

Power Supply Sequence and Handling Instructions

Since the IC is fabricated using InP HEMT process, users are recommended to follow the power supply sequence and the instructions below to prevent damage to the chip from electro-static discharge.

(1) Power Supply Sequence

- 1) Set V_{ss}, and GND to 0 V.
- 2) Apply power supply voltages V_{ss}.
- 3) Input data signal.

(2) Handling Precautions

- 1) Use a conductive working desk connected to the ground (or, a conductive table top connected to the ground).
- 2) Require all handling personnel to wear a conductive bracelet or wrist-strap connected to the ground through a 1 M-ohm resistor.
- 3) Ground all test equipment.
- 4) Ground all soldering iron tops.
- 5) Store IC's and other devices such as chip capacitors in their conductive carriers until they are soldered.
- 6) Use power supplies that do not generate over-voltages such as spikes. Many power supplies generate over-voltages when their outputs are turned on or turned off. To avoid these over-voltages, connect power supplies to V_{ss} after the power supply outputs are turned on and set to 0 V. Disconnect power supplies from V_{ss} after the power supply outputs are set to 0 V but before the outputs are turned off.

Caution

1. In order to improve products and technology, specifications are subject to change without notice.
2. When using the products, be sure the latest information and specifications are used.
3. Circuit drawings etc. shall be provided for the purpose of information only on application examples not for actual installation of equipment. NTT Electronics Corp. shall not assume any liability for damage that may result from the use of these circuit drawings etc. NTT Electronics Corp. shall not assent to or guarantee any rights of execution for patent rights of the third parties and other rights that may be raised for use of these circuit drawings.
4. To make a design, the products shall be used within the assured ranges with respect to maximum ratings, voltage, and radiation. NTT Electronics Corp. shall not take any responsibility for damage caused by neglecting the assured values or improper usage.
5. Though NTT Electronics Corp. makes every effort to improve quality and reliability, there is a risk that failure or malfunction may occur in semiconductors. It is therefore necessary that the purchasers should take responsibility for making a design that allows the products to operate safely on equipment and systems without any direct threat to the human body and/or property, should such failures or malfunction occur.
6. NTT Electronics Corp.'s semiconductor device products are designed to be used with multimedia networks communication equipment and related measuring equipment. They have not been developed for such equipment that may affect people's lives. Those who intend to use the products for special purposes that may affect human life as a result of failure or malfunction in the equipment using the products or that require extremely high reliability (e.g. life support, aircraft and space rockets, control in nuclear power facilities, submarine relays, control of operations, etc.) shall contact NTT Electronics Corp. before using the products. NTT Electronics Corp. shall not assume any liability for damage that may occur during operation of the products without prior consultation.
7. The product is controlled under the 'Foreign Exchange and Foreign Trade Law'. In the case of exporting this product, it is requested that you take necessary procedures to obtain prior approval from the Minister of Economy, Trade and Industry.
8. The product uses arsenic compound. Arsenic compound powder and vapor are dangerous for humans. Do not break, cut, crush or chemically destroy the products. To dispose of the products, follow the relevant regulations and laws; do not mix with general industrial waste and domestic garbage.
9. Any questions should be directed to the Sales Department of NTT Electronics Corp.

Copyright 2004
NTT Electronics Corp.